



MODEL NO: 15-21UGC/TR8

Device Number : DSE-151-081 REV. 1.0

**1206 Package Chip LEDs**

ECN : \_\_\_\_\_ Page: 1/8

**Features :**

- Package in 8mm tape on 7" diameter reel.
- Compatible with automatic placement equipment.
- Compatible with infrared and vapor phase reflow solder process.
- Mono-color type.

**Descriptions :**

- The 15-21 SMD Taping is much smaller than leaded components, thus enable smaller board size, higher packing density, reduced storage space and finally smaller equipment to be obtained.
- Besides, lightweight makes them ideal for miniature application, etc.

**Applications :**

- Automotive: backlighting in dashboard and switch.
- Telecommunication: indicator and backlighting in telephone and fax.
- Flat backlight for LCD, switch and symbol.
- General use.

**Package Dimensions :**

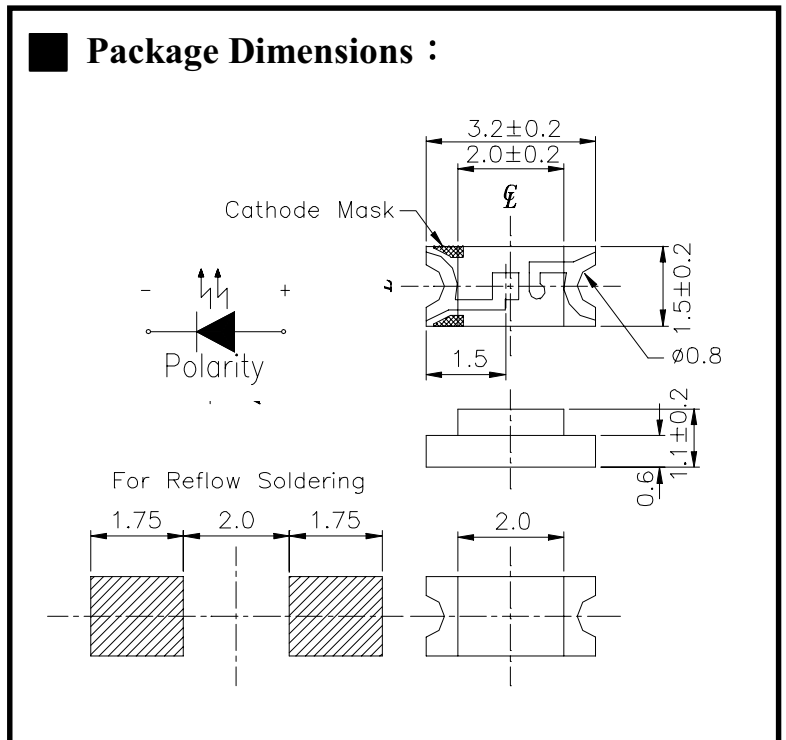

**Notes :**

- Tolerances Unless Dimension ± 0.1mm
- Angle ± 0.5°
- Unit = mm

PART NO	CHIP		Lens Color
	Material	Emitted Color	
15-21UGC/TR8(HT)	GaP	Super Green	Water Clear

Office: NO. 25, Lane 76, Sec.3, Chung Yang Rd., Tucheng 236, Taipei, Taiwan, R.O.C.

TEL: 886-2-2267-2000, 2267-9936

FAX: 886-2-2267-6244, 2267-6189, 2267-6306

http://www.everlight.com



EVERLIGHT ELECTRONICS CO., LTD.

MODEL NO: 15-21UGC/TR8

Device Number : DSE-151-081 REV. 1.0

**1206 Package Chip LEDs**

ECN : ..... Page: 2/8

■ **Package Dimensions :**

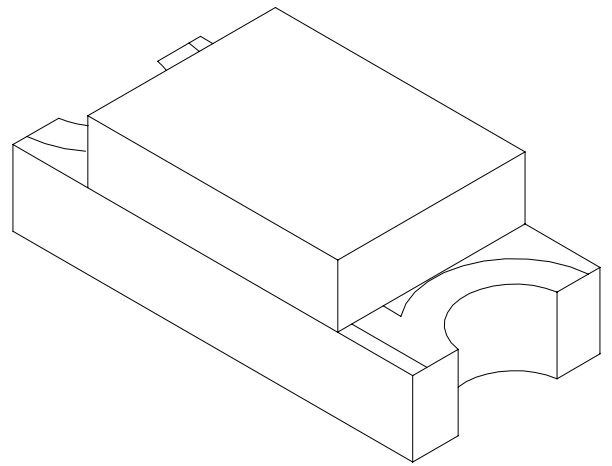
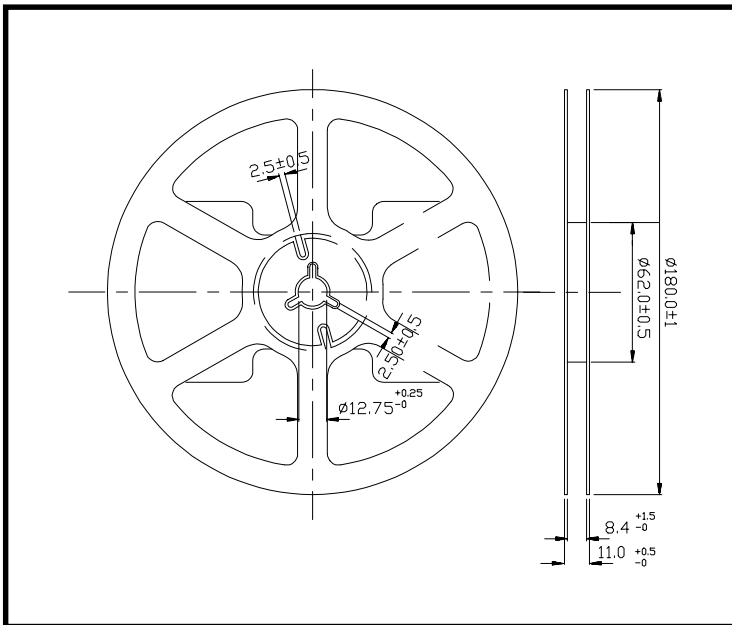

■ **Loaded quantity per reel 2000 pcs/reel :**

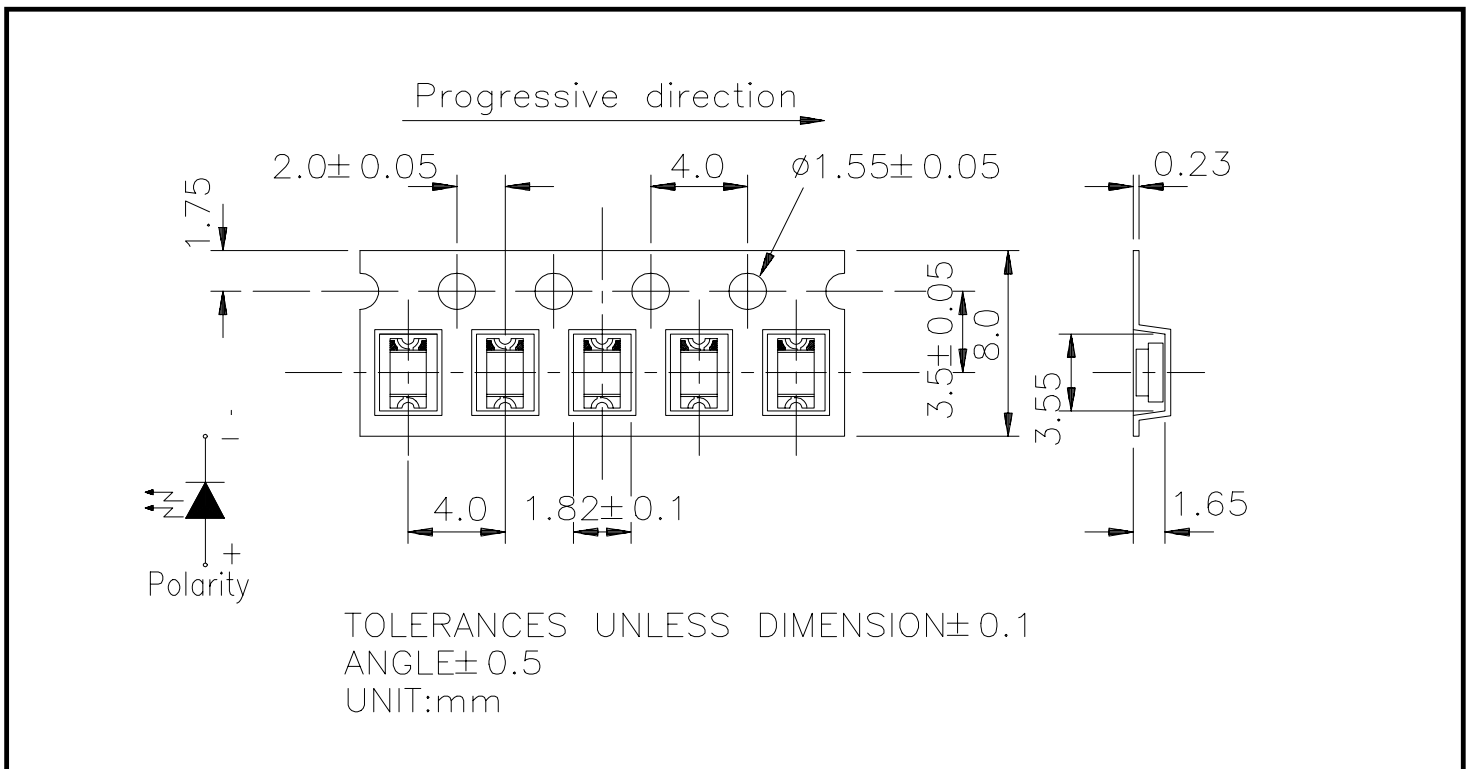



# EVERLIGHT ELECTRONICS CO., LTD.

MODEL NO: 15-21UGC/TR8  
**1206 Package Chip LEDs**

Device Number : DSE-151-081 REV. 1.0

ECN : \_\_\_\_\_ Page: 3/8

## ■ Absolute Maximum Ratings at Ta = 25°C

Parameter	Symbol	Rating	Unit
Reverse Voltage	Vr	5	V
Forward Current	If	30	mA
Operating Temperature	Topr	-40 ~ +85	°C
Storage Temperature	Tstg	-40~ +90	°C
Soldering Temperature	Tsol	260 (for 5 second)	°C
Power Dissipation	Pd	100	mW
Peak Forward Current(Duty 1/10 @ 1KHZ)	If(Peak)	160	mA

## ■ Electronic Optical Characteristics :

Parameter	Symbol	Min.	Typ.	Max.	Unit	Condition
Luminous intensity	Iv	8	15	-----	mcd	If=20mA
Viewing Angle	2θ 1/2	-----	140	-----	deg	If=20mA
Peak Wavelength	λp	-----	570	-----	nm	If=20mA
Dominant Wavelength	λd	-----	571	-----	nm	If=20mA
Spectrum Radiation Bandwidth	△λ	-----	30	-----	nm	If=20mA
Forward Voltage	Vf	1.7	2.1	2.4	V	If=20mA
Reverse Current	Ir	-----	-----	10	μA	Vr=5V



# EVERLIGHT ELECTRONICS CO., LTD.

MODEL NO: 15-21UGC/TR8  
*1206 Package Chip LEDs*

Device Number : DSE-151-081 REV. 1.0

ECN : \_\_\_\_\_ Page: 4/8

## ■ Reliability Test Item And Condition

NO	Item	Test Conditions	Test Hours/Cycle	Sample Size	Ac/Re
1	Solder Heat	TEMP : 260°C ± 5 °C	5 SEC	76 Pcs	0/1
2	Temperature Cycle	H : +85°C 30min ∫ 5 min L : -55°C 30min	50 CYCLE	76 Pcs	0/1
3	Thermal Shock	H : +100°C 5min ∫ 10 sec L : -10°C 5min	50 CYCLE	76 Pcs	0/1
4	High Temperature Storage	TEMP : 100°C	1000 HRS	76 Pcs	0/1
5	Low Temperature Storage	TEMP : -55°C	1000 HRS	76 Pcs	0/1
6	DC Operating Life	If = 20 mA	1000 HRS	76 Pcs	0/1
7	High Temperature / High Humidity	85°C/85% RH	1000 HRS	76 Pcs	0/1



MODEL NO: 15-21UGC/TR8  
**1206 Package Chip LEDs**

Device Number : DSE-151-081 REV. 1.0

ECN : \_\_\_\_\_ Page: 5/8

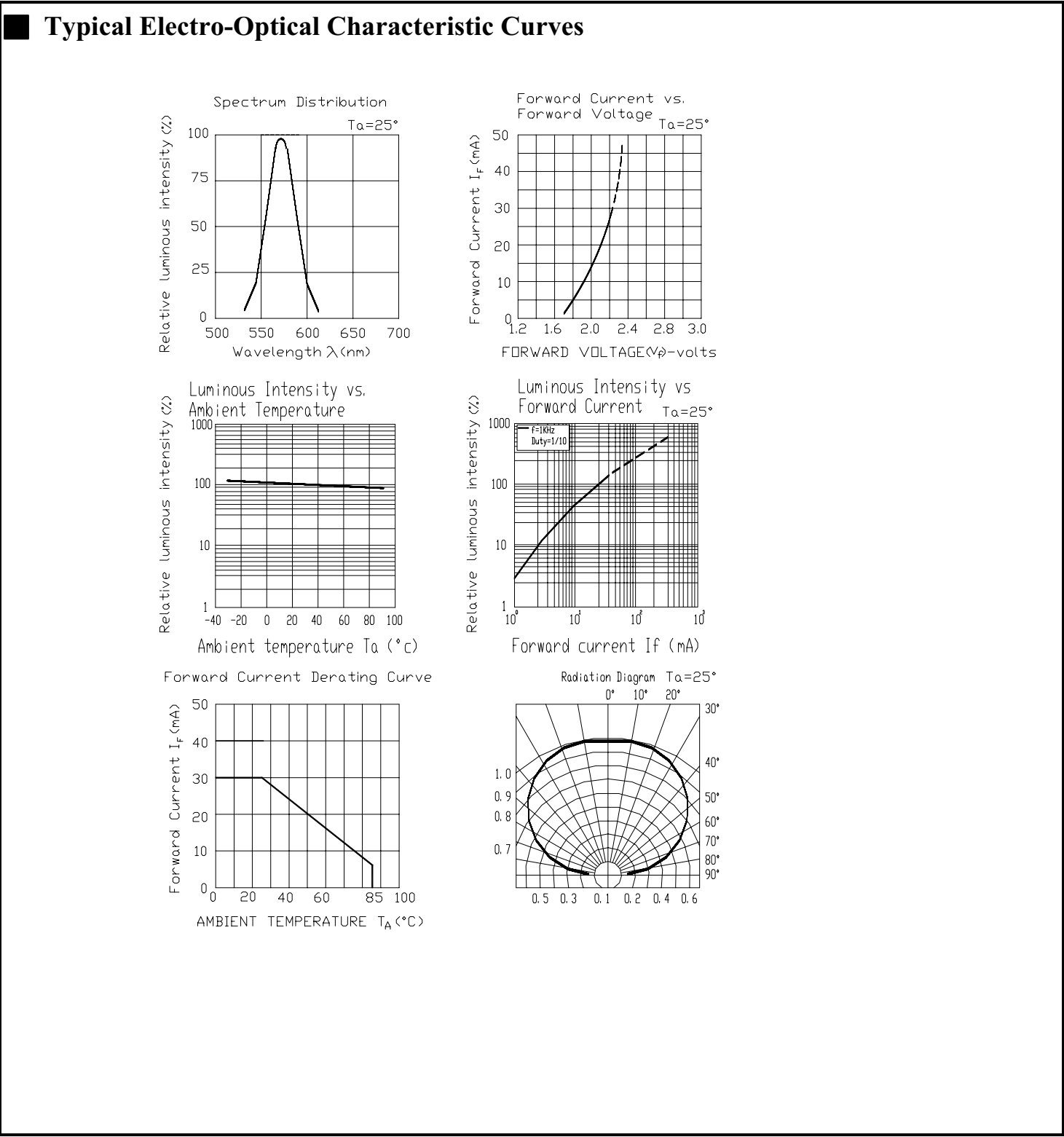



EVERLIGHT ELECTRONICS CO., LTD.

MODEL NO: 15-21UGC/TR8  
*1206 Package Chip LEDs*

Device Number : DSE-151-081 REV. 1.0

ECN : ..... Page: 6/8

## ■ Test Circuit

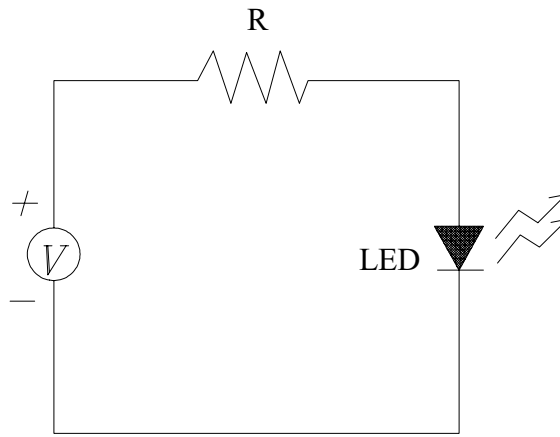

## ■ Precautions For Use

### 1. Over-current-proof

Customer must apply resistors for protection , otherwise slight voltage shift will cause big current change ( Burn out will happen ).

### 2. Storage time

2.1 The operation of temperature and R.H. are :  $5^{\circ}\text{C}\sim 35^{\circ}\text{C}$  , R.H.60%.

2.2 Once the package is opened, the products should be used within a week.  
Otherwise, they should be keeping in a dampproof box with desiccants.  
Considering the tape life , we suggest our customers to use our products within a year(from production date).

2.3 If opened more than one week in an atmosphere  $5^{\circ}\text{C}\sim 35^{\circ}\text{C}$  , R.H.60%, they should be treated at  $60^{\circ}\text{C}\pm 5^{\circ}\text{C}$  for 15hrs.

2.4 When you discover that the desiccant in the package has a pink color (Normal = blue) , you should treat them in the same conditions as 2.3.



# EVERLIGHT ELECTRONICS CO., LTD.

MODEL NO: 15-21UGC/TR8  
**1206 Package Chip LEDs**

Device Number : DSE-151-081 REV. 1.0

ECN : ..... Page: 7/8

## ■ Soldering heat reliability ( DIP )

Please refer to the following figure :

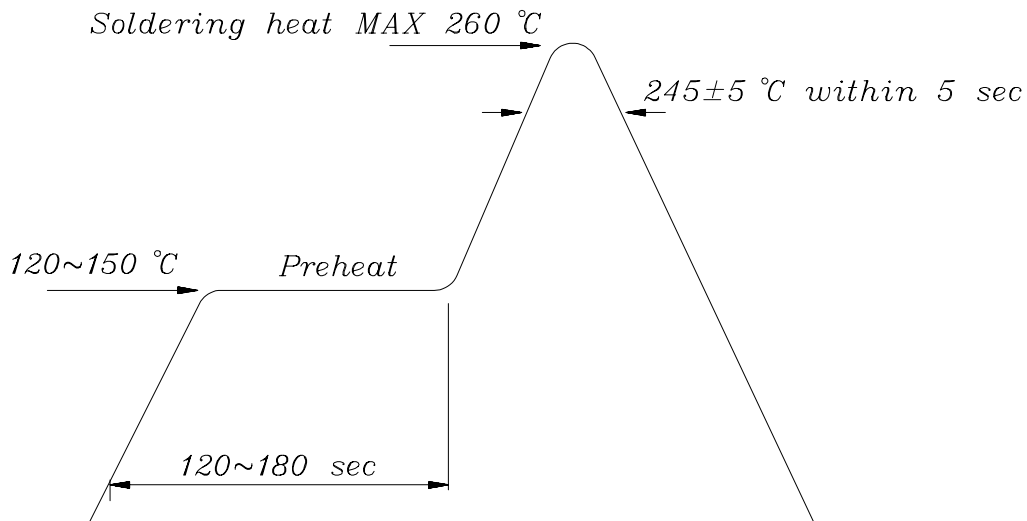

## ■ Soldering Iron

Basic spec is  $\leq 5$  sec when 260°C. If temperature is higher, time should be shorter (+10°C → -1sec). Power dissipation of iron should be smaller than 15 W , and temperature should be controllable. Surface temperature of the device should be under 230 °C.

## ■ Rework

1. Customer must finish rework within 5 sec under 260°C.
2. The head of iron can not touch copper foil.
3. Twin-head type is preferred.

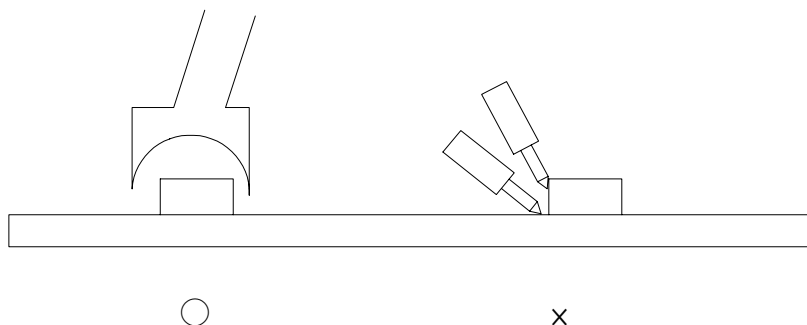



EVERLIGHT ELECTRONICS CO., LTD.

MODEL NO: 15-21UGC/TR8

Device Number : DSE-151-081 REV. 1.0

**1206 Package Chip LEDs**

ECN : ..... Page: 8/8

■ Reflow Temp / Time :

